

P 054  
Yorckstraße 1a

41564 Kaarst-Büttgen

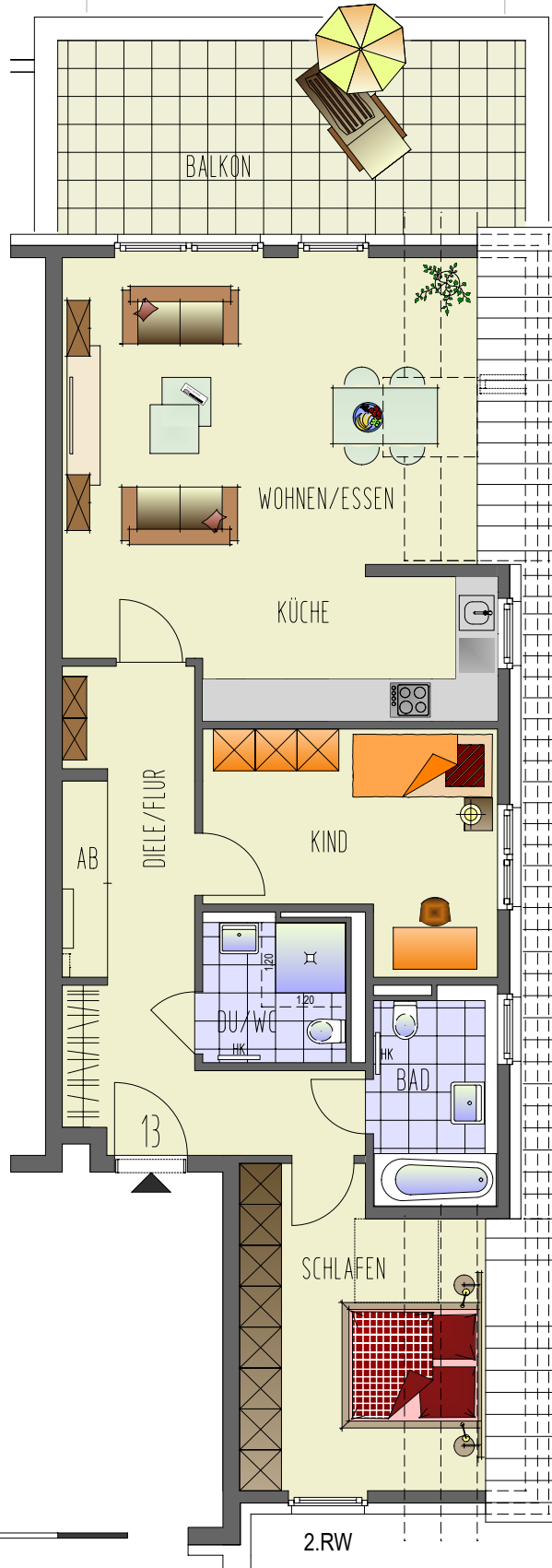

## Wohnung 13

3-Raum-Wohnung  
Dachgeschoss, rechts

Wohnen / Essen	28,77 m <sup>2</sup>
Schlafen	12,69 m <sup>2</sup>
Kind	12,49 m <sup>2</sup>
Küche	7,00 m <sup>2</sup>
Bad	5,45 m <sup>2</sup>
DU/WC	4,29 m <sup>2</sup>
Diele / Flur	14,03 m <sup>2</sup>
Abstellen	1,83 m <sup>2</sup>
<b>Balkon 18,66 m<sup>2</sup> (50%)</b>	<b>9,33 m<sup>2</sup></b>

Wohnfläche 95,88 m<sup>2</sup>

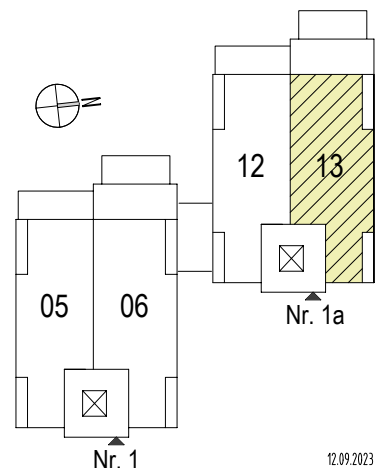

1.00